

LCD connection for:
 m_lcde.asm (std. char set, delay-based)
 m_lcdbf.asm (std. char set, busy-flag based)
 m_lcdexbf.asm (ext. char set, busy-flag based)

LCD connection for:
 m_lcd.asm (std. char set, delay-based)
 m_lcdx.asm (ext. char set, delay-based)
 m_lcd_bf.asm (std. char set, busy-flag based)
 m_lcdxbf.asm (ext. char set, busy-flag based)

Dot Matrix LCD Display
 (HD44780 compatible)

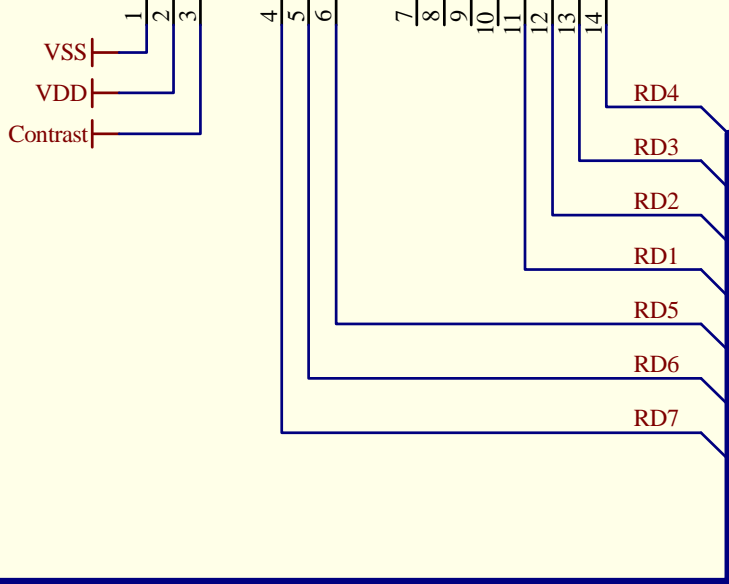
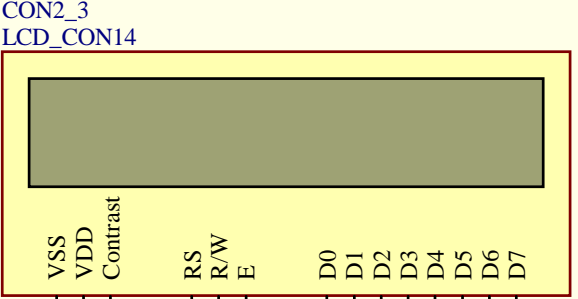
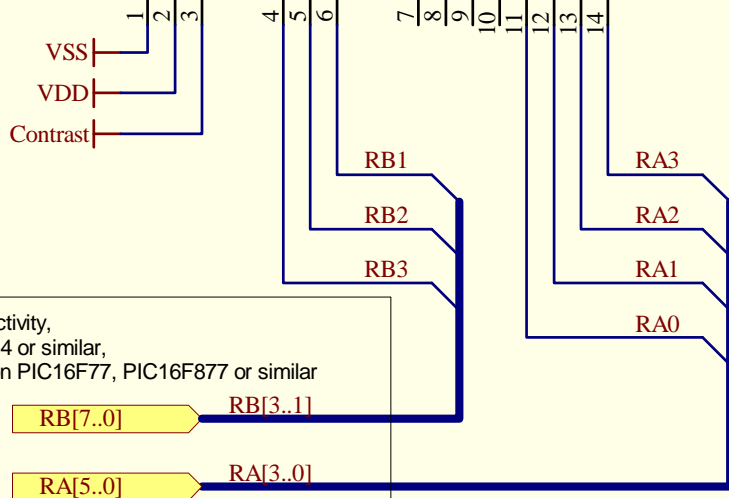
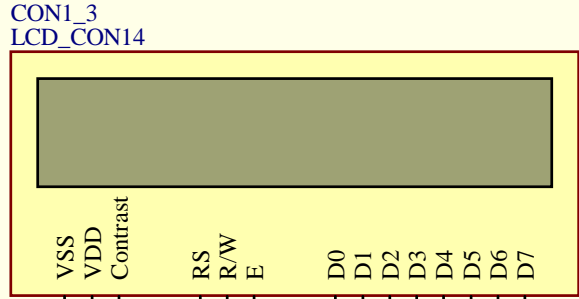
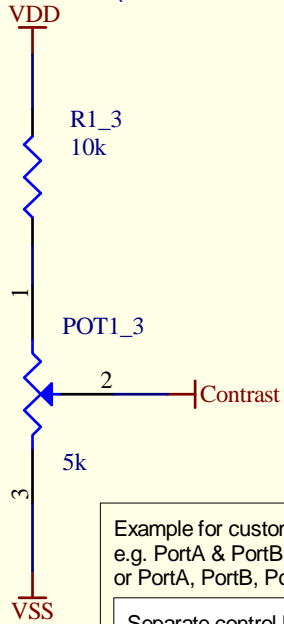

Example for customized connectivity,
 e.g. PortA & PortB on PIC16F84 or similar,
 or PortA, PortB, PortC, PortD on PIC16F77, PIC16F877 or similar

Separate control lines **RB[7..0]** **RB[3..1]**

Data lines on low nibble **RA[5..0]** **RA[3..0]**

Data & control lines on a single port **RD[7..0]** **RD[7..1]**

Example connectivity for a single port,
 e.g. PortB on PIC16F84 or similar,
 or PortB, PortC, PortD on PIC16F77, PIC16F877 or similar

Title
HD44780 Dot Matrix LCD Connectivity

Written by
 Peter Lüthi
 www.electronic-engineering.ch
 Urdorf, Switzerland

Date
 5-Jun-2005

Revision 1.00 Page 1 of 1